



Gesellschaft für
Hardware•Software•Produktion GmbH

HSP GmbH Zum Handwerkerhof 2 90530 Wendelstein Tel. 09129 / 2852-0 Fax: 09129 / 2852-11 Web: www.hsshsp.de EMAIL: HSP@hsshsp.de

NTG-3000

Transducer

Operating Instructions

Document Version 2.9

Software Version 3.7

Versions / Revisions:

Document version	Creation date	Author	Description
2.0	2012-07-25	P. Compensis	First official version
2.1	2012-09-17	P. Compensis	Description for software version 3.2
2.2	2012-10-16	P. Compensis	Description for software version 3.2 Distinction between modes 2 and 2+
2.3	2012-02-22	P. Compensis	Description for software version 3.3: Integrated filters
2.4	2013-03-07	P. Compensis	Specification of software and hardware versions in the description of the documents validity. In chapter 7.3 “Measuring inputs” the limitation of cable length was removed. Addition of information for filter types. Addition of graphical display of the algorithm for second order filters. Description of the third filter level. Revision of the connection diagram.
2.5	2013-05-16	B. van Laak	Rotation of the housing by 180 °.
2.6	2013-09-10	C. Aggou	Addition of the “Algorithms”-Section
2.7	2013-11-25	C. Aggou	Addition of the description of the input filter
2.8	2013-12-16	P. Compensis C. Aggou	Various small corrections Addition of a diagram of the Cherbyshev-Filter
2.9	2014-04-16	P. Compensis	New Software Version



Contents:

1	INTRODUCTION.....	4
2	SCOPE OF APPLICATION OF THIS DOCUMENT	4
3	TRANSPORT AND STORAGE.....	4
4	ENVIRONMENT CATEGORY	4
5	INSTALLATION INSTRUCTIONS.....	4
6	CONNECTION	6
7	DESCRIPTION OF DESIGN OF CONNECTIONS.....	7
8	CONFIGURATION.....	8
9	LEDS	9
10	STARTUP	9
11	MEASURED VALUE ACQUISITION.....	10
12	FILTER.....	12
13	ALGORITHMS.....	14
14	DATA TRANSMISSION.....	15
15	ERROR SIGNALING	15

1 Introduction

This transformer is used in power plants. It forms part of a control circuit that acquires actual values for the currents and voltages of a generator and forwards them to the control unit via Ethernet/PROFIBUS.

This document describes installation, connection and startup of the transducer.

2 Scope of application of this document

These Operating Instructions only apply to transducer NTG-3000.

Software Version 3.5

Hardware Rev. 5.1

3 Transport and storage

3.1 Storage temperature

-20°C to +70°C, maximum rate of change: 20 K/h
IEC 60068-2-1 and IEC 60068-2-2

3.2 Mechanical strength

When stationary:	DIN IEC 60068-2-6
Deflection:	0.075 mm (5 - 9 Hz)
Acceleration:	1 m/s ² (>9 -200 Hz)
During transport:	DIN IEC 60068-2-6
Deflection:	3.5 mm (5 - 9 Hz)
Acceleration:	10 m/s ² (>9 -500 Hz)

4 Environment category

Environment 2 as per EN 61800-3.

5 Installation instructions

The device is designed for installation on a standard DIN mounting rail (DIN EN 60715 TH 35). Other methods of mounting are not permitted.

Permissible mounting position: Horizontal

5.1 Installation

The following steps must be performed for installing the device:

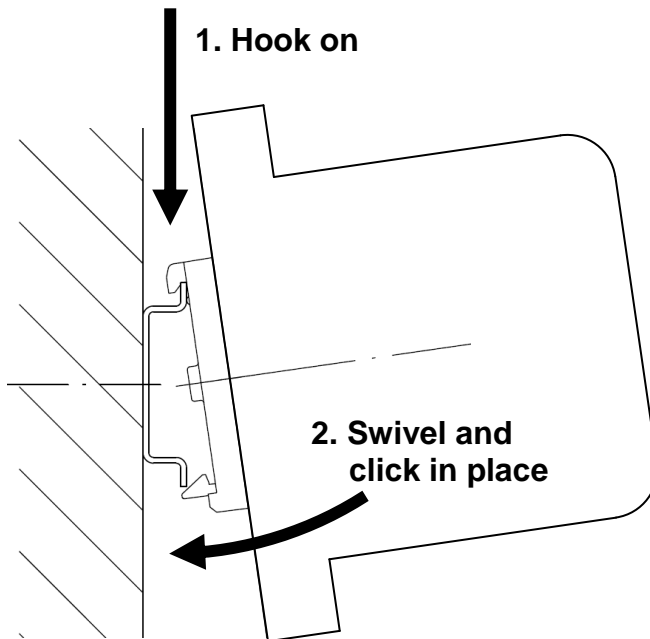

5.2 Removal

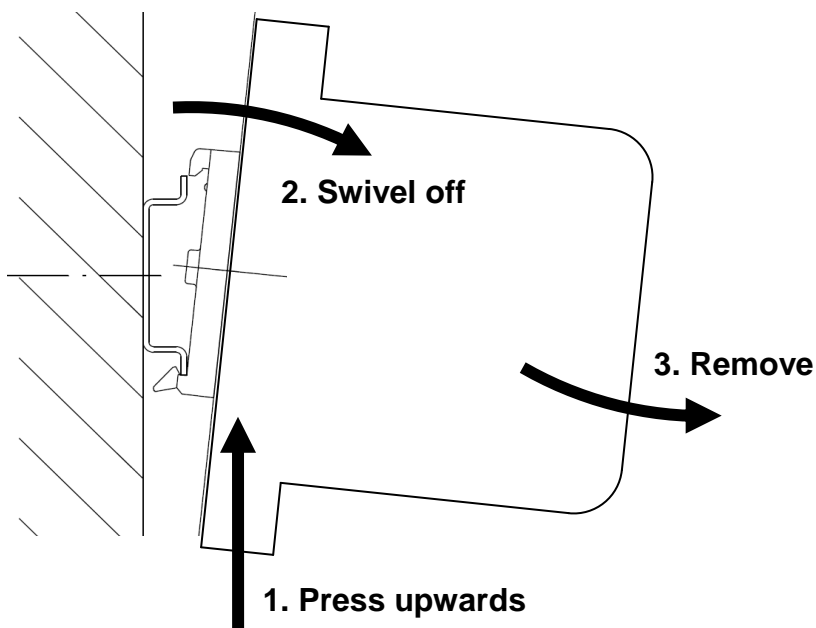

6 Connection

A protective conductor (PE) and the voltage supply must always be connected (terminal X100). All other connections are optional for the purposes of operation.

6.1 Connection diagram

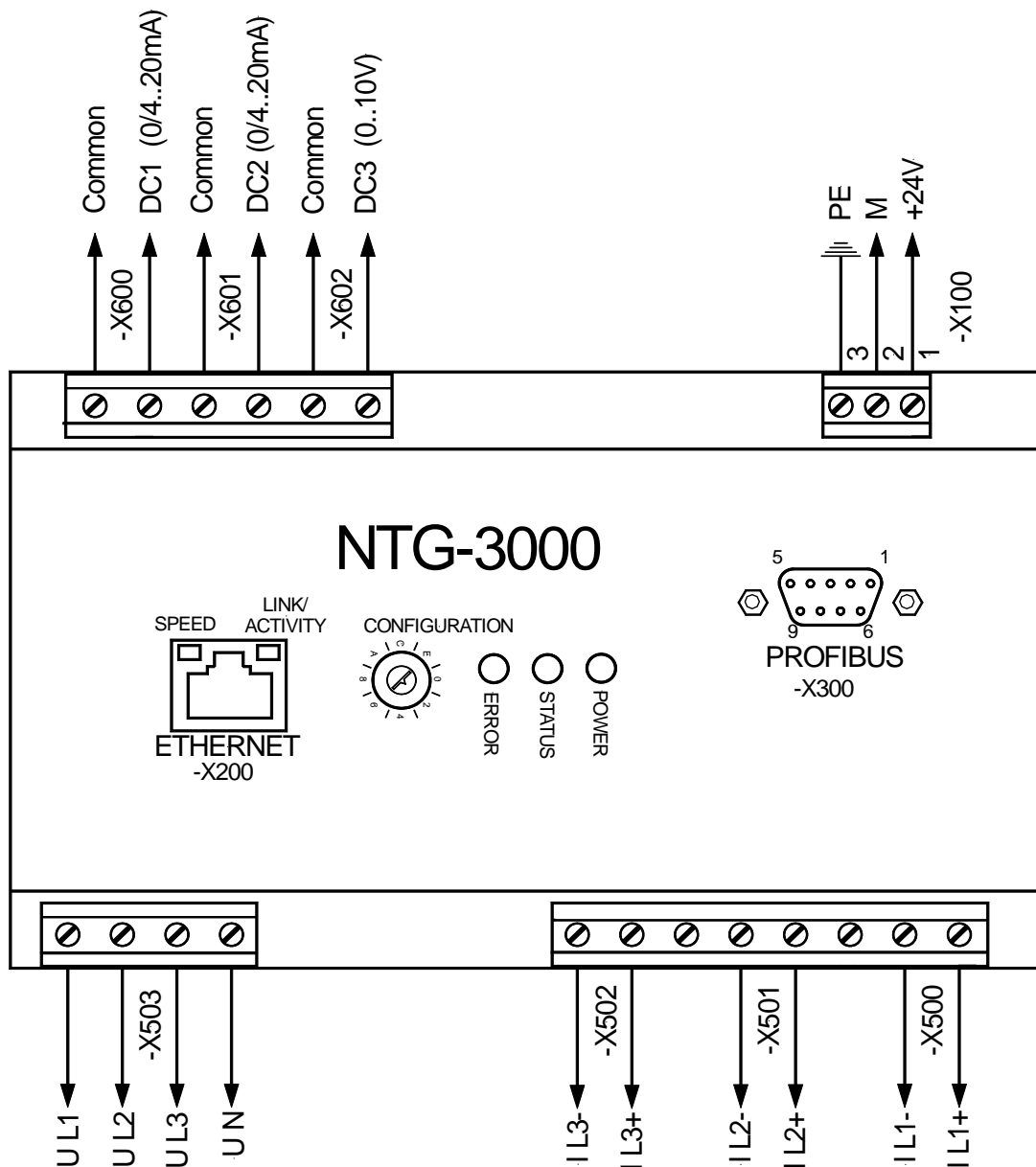

7 Description of design of connections

7.1 Connection of protective conductor (PE)

Before the device is placed in operation, a connection must be established between protective conductor terminal X100/3 and the PE potential of the place of installation.

A flexible PE cable (green/yellow) must be provided with a minimum cross section of 1.5 mm^2 . The cable should be as short as possible ($<2 \text{ m}$).

7.2 Connection of voltage supply

The supply voltage is connected to terminals X100/1 (+24V) and X100/2 (M). The cable length must be less than 30 m. The device is not equipped with a power switch.

The 24 V DC power supply must be adapted to the input data of the device; see data sheet.

7.3 Measuring inputs

The cables connected to the measuring inputs (terminal strips X500, X501, X502, X503, X600, X601, X602) must be shielded and as short as possible (cable length above 100 m must be examined regarding measurement uncertainty). Any power or main voltage cables or any other cable afflicted by interference shall not be lay parallel to the signal lines. Note the common EMC planning rules.

7.4 Ethernet interface

An 8P8C modular connector or “RJ-45”(X200) is used for connection to an Ethernet cable in accordance with the specification 100BASE-TX, IEEE 802.3 Clause 25.

7.5 PROFIBUS interface

The transducer is equipped with a 9-pin D-Sub socket (X300) for connection to PROFIBUS.

8 Configuration

The transducer must be configured for the connected signals (terminal strips X500 to X503 and X600 to X602) before it is placed in operation for the first time. The 16-position rotary switch labeled “*CONFIGURATION*” is used for configuration.

Note: The rotary switch is only evaluated during system startup (when the supply voltage is connected). Changes can be made to the settings of the rotary switch during operation but these will have no impact on the system until the next startup.

8.1 Possible switch settings / configurations

The mode is selected using the 16-position rotary switch:

Setting	Currents:		DC signals		Mode	3-phase (I1, I2, I3) 2-phase (I1, I3)	
	1 A	5 A	0 to 20 mA	4 to 20 mA			
0	X		X		2 (without debug data)	3-phase	
1	X			X	2 (without debug data)		
2		X	X		2 (without debug data)		
3		X		X	2 (without debug data)		
4	X		X		2+ (with debug data)		
5	X			X	2+ (with debug data)		
6		X	X		2+ (with debug data)		
7		X		X	2+ (with debug data)		
8	X		X		1		
9	X			X	1		
A		X	X		1		
B		X		X	1		
C	X		X		2 (without debug data)		2-phase
D	X			X	2 (without debug data)		
E		X	X		2 (without debug data)		
F		X		X	2 (without debug data)		

9 LEDs

LED	Description		Color
POWER	Lit when operating voltage is present		Green
STATUS	To indicate operation and errors (see 15.1)		Green
ERROR	To indicate error conditions (see 15.1)		Red
Ethernet Link/Activity	Not lit	No link	Yellow
	Lit	Link	
	Flashing	Activity / network traffic	
Ethernet Speed	Not lit	10Base-T	Green
	Lit	100Base-TX	

10 Startup

The device must be configured as described in Section 8 prior to startup. The supply voltage can then be connected. Once the initialization phase is complete, cyclic measured value acquisition starts automatically and, if an Ethernet link is available, the transducer starts to send a continuous stream of measured values to the permanently programmed target IP address (see Section 14.1).

At the same time, the values can be queried via the PROFIBUS interface (see Section 14.2).

11 Measured value acquisition

11.1 Filtering of the analog inputs (U1–3 and I1–3)

The analog inputs (U1–3 and I1–3) are filtered by default. This filtering can be disabled via the option byte (see NTG 3000 - Data protocol).

The implemented filter is a Chebyshev filter second degree and has the following coefficients:

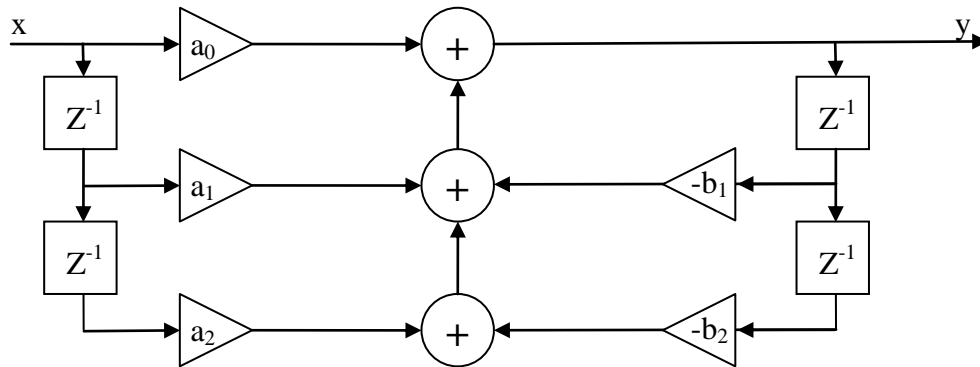

$$a_0 = 0.134121405$$

$$a_1 = 0.268242810$$

$$b_1 = -0.740464862$$

$$a_2 = 0.134121405$$

$$b_2 = 0.276950483$$

11.2 Scan Rate of the analog inputs

The measured values are read at different rates in the different modes:

	Scan Rate	
Mode 1	100 μs	2 ms
Mode 2	500 μs	2 ms
Channel	U1	DC1
	U2	DC2
	U3	DC3
	I1	
	I2	
	I3	

Note: If the analog input filter is enabled, the advanced phase failure detection (see 12.2) and the rate-of-change filter (see 12.3) are disabled!

12 Filter

For the filtered compensated frequency ($f_{\text{comp filtered}}$) and the filtered effective power (P_{filtered}) there are three filters of second order integrated.

The layout of filter structures will be described in the following chapters.

12.1 Layout of filter structures

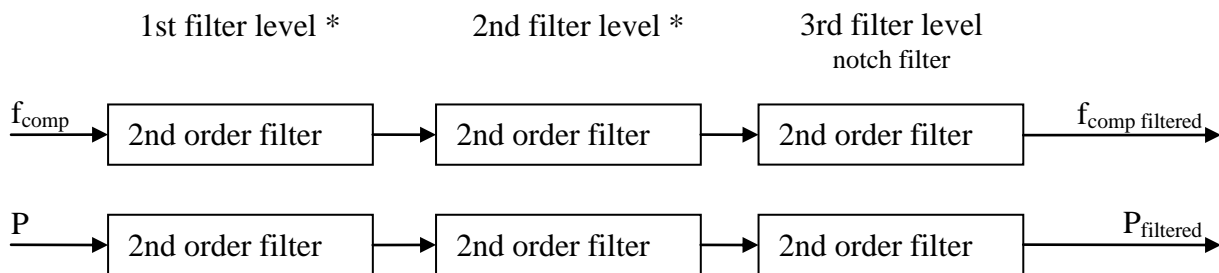

* depending to the filter parameters, e.g. Butterworth (see section 12.3)

12.2 Algorithm of second order filter

$$y = b_2 \cdot x + b_1 \cdot x_{k-1} + b_0 \cdot x_{k-2} - a_1 \cdot y_{k-1} - a_0 \cdot y_{k-2}$$

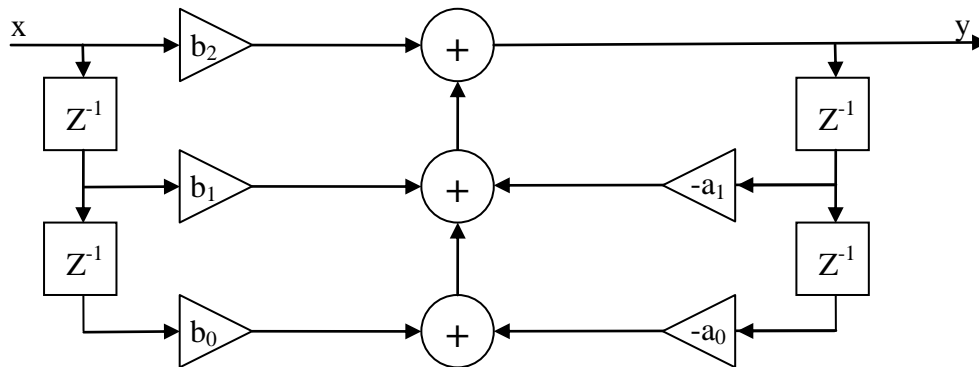

- x filter Input
- y filter Output
- Z^{-1} clock delay
- x_{k-1} value at filter input with delay of one clock
- x_{k-2} value at filter input with delay of two clocks
- y_{k-1} value at filter output with delay of one clock
- y_{k-2} value at filter output with delay of two clocks

- $b_0 \dots b_2$
- $a_0 \dots a_1$ filter parameters

12.3 Filter parameters of the first and second filter level

The parameters of the first and second filter level must be parameterized over Profibus (see section “Settings via PROFIBUS” in the description of protocol for data transmission).

12.4 Fixed filter parameters of the third filter level

The fixed parameters of the third filter level will be switched automatically according to the parameter f_0 (rated frequency). Both sets of parameters for the third filter level are integral part of the firmware and cannot be parameterized over PROFIBUS.

The third filter level (notch filter) is only activated when the basic frequency is parameterized with 50 Hz or 60 Hz. In other cases the third filter level will be deactivated (filter input = filter output).

12.4.1 Parameters at $f_0 = 50$ Hz, notch filter (third filter level)

$$\begin{array}{lll} b_2 = 0.961738506 & b_1 = -1.899795818 & b_0 = b_2 \\ & a_1 = -1.900784057 & a_0 = 0.924465250 \end{array}$$

12.4.2 Parameters at $f_0 = 60$ Hz, notch filter (third filter level)

$$\begin{array}{lll} b_2 = 0.9543227349 & b_1 = -1.8748381111 & b_0 = b_2 \\ & a_1 = -1.8762498820 & a_0 = 0.9100572407 \end{array}$$

13 Algorithms

The *NTG-3000* is equipped with various algorithms to catch errors and to detect and to display them.

13.1 Simple Phase Failure Detection

At each system cycle the simple phase failure detection examines, whether the sum of the phase voltage is within a threshold around zero. If the sum is greater than the threshold, because one or two phase are cut off, a voltage phase failure is flagged with Bit 1 in the **Error-Byte** (see *NTG-3000 – Description of Protocol for Data Transmission*).

Disadvantage of this phase failure analysis method:

- In three-phase systems the neutral wire has to be connected, otherwise the algorithm does not work
- The failure of three voltage phases is not recognized

13.2 Advanced Phase Failure Detection

The extended voltage phase failure detection compares at each system-cycle the values of the individual phases together. In case of failure of one, two or three phases the comparison fails. Via Bit 2 in the **Error-Byte** (*NTG-3000 – Transducer*) an error is displayed via PROFIBUS and Ethernet.

In this case the algorithm operates as described in the document *PT_Failure_Supervision_2013_09_03*.

Note: If the analog input filter is enabled (see 11), the advanced phase failure detection (see 12.2) is disabled!

13.3 Rate-of-Change-Limiter

The *Rate-of-Change-Filter* prevents, that the calculated compensated frequency ($f_{comp\ gefiltert}$) makes a step in case of a phase failure. This cannot physically occur due to the inertia of the generator. The filter limits the change of the compensated frequency to a value. This value is calculated by a predetermined parameter (*Inertia of the synchronous machine H* see *NTG-3000 - Transducer*).

The limits are calculated like this:

$Max = (T_{cycle} * I/H)$; in which T_{cycle} specifies the time period, by which the Rate-of-Change-Limiter algorithm is performed.

$Min = -Max$

The limited compensated frequency is calculated using the following formula:

$$f_{comp\beta n} = \lim_{min}^{max} (f_{comp\ gefiltert} - f_{comp\beta n-1}) + f_{comp\beta n-1}$$

Note: If the analog input filter is enabled (see 11), the rate-of-change filter is disabled!

14 Data transmission

14.1 Ethernet

The transducer sends the measured values for all channels to target IP address **192.168.1.100** cyclically in a UDP packet.

14.2 PROFIBUS

The measured values for all channels are transmitted to the PROFIBUS master upon request.

14.3 Data format

A description of the structure of the data transmitted via Ethernet or PROFIBUS can be found in the document: *“Transducer Data Protocol”*.

15 Error signaling

Error conditions are indicated by means of the ERROR LED. The exact error types are also transmitted via Ethernet and PROFIBUS (see document *“Transducer Data Protocol”*).

15.1 Status and error LEDs

STATUS LED (green)	ERROR LED (red)	
ON	OFF	Normal operation
1 Hz	OFF	System startup (for approx. 2 seconds) or during initialization of an Ethernet link
2 Hz	5 Hz	PROFIBUS error
5 Hz	ON	Unexpected, serious error
OFF	ON	EEPROM error
ON	ON	Incorrect calibration values
ON	2 Hz	Invalid rotary switch setting = invalid configuration

1 Hz: LED flashes at 1 Hz 2 Hz: LED flashes at 2 Hz 5 Hz: LED flashes at 5 Hz

15.2 Troubleshooting

- Error description: **The POWER LED (see Section 6) is not lit.**
Action: Check the supply voltage (see Section 0).
- Error description: **The red ERROR LED is not permanently off.**
Action: The ERROR LED signals a range of different errors. Please refer to the table in Section 15.1.
- Error description: **The green STATUS LED is not permanently lit.**
Action: The STATUS LED signals a range of different operating conditions. Please refer to the table in Section 15.1.
- Error description: **The transducer is signaling a PROFIBUS error.**
Action: Check the PROFIBUS connection between the transducer and the master (see Section 7.5). Restart the transducer and the master (by temporarily interrupting the supply voltage, see Section 0).
- Error description: **The transducer is signaling an “unexpected, serious program error”.**
Action: Restart the transducer by temporarily interrupting the supply voltage (see Section 0).
- Error description: **Unexpected data have been sent by the transducer**
or
the transducer is signaling “Invalid rotary switch setting = Invalid configuration”.
Action: Check the rotary switch setting (see Section 0).
- Error description: **No data are being received from the transducer via Ethernet.**
Action: Check the IP address of the receiver (see Section 13) and the Ethernet cable connection (see Section 7.4).
- Error description: **The PROFIBUS master cannot connect to the transducer.**
Action: Check the slave address and check that the correct GSD file has been selected (see document “Transducer Data Protocol”).
- Error description: **The transducer is signaling “EEPROM error” or “Incorrect calibration values”.**
Action: Return the device to the manufacturer.